

is stopped. When operating in analog mode, be careful not to exceed the decoder's input voltage rating of 26 Volts. When your track voltage exceeds 28 Volts, the decoder will automatically shut off the sound and motor: back down on the throttle immediately.

**Power Supply**

Important: Your sound decoder will work best in analog mode when using a high quality, electronically regulated power pack, preferably one that supplies smooth, filtered DC power. Older rheostat style power packs and pulse power packs will result in erratic and unreliable operation and should NOT be used with this sound decoder.

**Operating the Model**

Once the throttle has achieved sufficient voltage, if the throttle is set to move the locomotive forward, two blasts of the whistle (except Toby) will sound as the throttle is increased. Increasing the throttle further will set the locomotive in motion, increasing speed as the throttle is increased. The exhaust chuff is synchronized to the speed of the locomotive. Once the locomotive has reached and maintained a constant speed, the whistle will sound approximately every 20 seconds. **If the throttle is decreased slowly to stop, you will also hear a steam release effect just before stopping.**

**Adjusting the Master Volume in DC**

If your locomotive has a volume control potentiometer, turn the knob clockwise to turn on the audio portion of the sound decoder. This will not affect the operation of the motor, but allows you to increase or decrease the overall volume of all the sound effects simultaneously. Turn the knob all the way counter-clockwise to turn the audio off.

**Use of the "Polarity" Switch**

Due to varying standards, if you are running in analog mode with a DC power pack, you may set the locomotive's default direction of travel with the "polarity" switch under the model if your locomotive is equipped with a polarity switch. Set to "Large Scale" or "NMRA" according to your preference. When running in DCC, changing this switch has no effect.



COMPATIBLE WITH THE NMRA DCC STANDARDS AND RECOMMENDED PRACTICES



# Instructions for Bachmann® Large Scale Thomas & Friends™ DCC Sound Module

DCC Sound Technology by SoundTraxx®

- 16-Bit Sound Processor
- Automatic Dual Mode Decoder for DC and DCC Operation

Bring the sounds of Sodor to life with this separate-sale Sound Module for installation in your Large Scale *Thomas & Friends™* engines! Solder pad installation and customer-supplied speaker required. Sound package includes whistle or bell per prototype, chuff, and cylinder blow down. Also controls customer-installed headlamp(s) if desired. Character sound suites available through DCC CV selection only. Character sound suites include Thomas, Percy, James, Edward, Henry, Gordon, Emily, Spencer, and Toby. Approximate board dimensions: 60mm x 30mm x 15mm. Factory preset for Thomas sound suite. Designed for Large Scale use only.

**Troubleshooting Checklist**

1. If there is no sound, be sure the volume control knob has not been turned all the way off.
2. If operating in DCC mode, follow the "Starting Over" instructions to reset the locomotive to factory default settings.

For service/repair, contact the Bachmann Service Department by visiting [www.bachmanntrains.com/home-usa/service.php](http://www.bachmanntrains.com/home-usa/service.php), calling 1-800-356-3910 (toll-free within the U.S. and Canada), calling 215-533-1600 (for all countries), or emailing [service@bachmanntrains.com](mailto:service@bachmanntrains.com). Bachmann's Service Department is available Monday through Friday, 8:00 am to 4:00 pm ET. Please be aware you may need to leave a message on our voice mail system. Your call will be returned as soon as a service technician is available. We thank you in advance for your patience.

**Notice**

The information in this document is subject to change without notice. Neither Bachmann Industries, Inc. nor SoundTraxx (Throttle Up!) shall be liable for technical or editorial errors or omissions contained herein; nor for incidental or consequential damages resulting from the furnishing, performance or use of this material. This document contains information protected by copyright. No part of this document may be photocopied or reproduced in any form without the prior written consent of Bachmann Industries, Inc. Product names mentioned herein may be trademarks and/or registered trademarks of their respective companies. Bachmann and Spectrum are registered trademarks of Bachmann Industries, Inc. SoundTraxx and Tsunami are registered trademarks of Throttle Up! Corp. SoundTraxx DCC, Digital Sound Decoder, Dynamic Digital Exhaust, Auto-Exhaust and Hyperlight are trademarks of Throttle Up! Corp. © 2016 Gullane (Thomas) Limited

## 90 DAY LIMITED WARRANTY FOR SOUND MODULE

purchased in the United States and Canada

effective November 1, 2011, this warranty supersedes all previous (and/or concurrent) warranties

This sound module is warranted to the original purchaser for a period of ninety (90) days from the original purchase date — under normal use and service — against defective materials or workmanship. This warranty is given in lieu of all other express warranties. All implied warranties, including but not limited to implied warranties of fitness and merchantability, shall expire ninety days from the date of purchase. Some jurisdictions do not allow limitations on how long an implied warranty lasts, so the above limitation may not apply to you.

This warranty is void if the component has been damaged by accident or unreasonable use, neglect, improper service or other causes including improper installation not arising out of defects in material or workmanship. BACHMANN SHALL NOT BE LIABLE FOR INCIDENTAL OR CONSEQUENTIAL COSTS, EXPENSES OR DAMAGES INCURRED BY THE PURCHASER. Some jurisdictions do not allow the exclusion or limitation of incidental or consequential damages, so the above limitation or exclusion may not apply to you.

This warranty gives you specific legal rights, and you may also have other rights which vary from location to location. In order to validate this warranty, the accompanying Owner Registration Card must be completed and mailed within ten (10) days after purchase of the module to the address listed below:

Send Owner Registration Card and direct inquiries to:

Attention: Service Department  
 Bachmann Industries, Inc.; 1400 East Erie Avenue; Philadelphia, PA 19124 USA  
 Telephone: 800-356-3910 (toll free within the United States and Canada only)  
 Telephone: 215-533-1600 (for all countries)  
 E-mail: [service@bachmanntrains.com](mailto:service@bachmanntrains.com)

For residents of the U.S. and Canada only, please fill in and mail this card within 10 days after purchase to validate warranty. PLEASE PRINT.

Pour les résidents des É.-U. et du Canada seulement : prière de remplir cette fiche et de la poster dans un délai de 10 jours après l'achat afin de valider la garantie. PRIÈRE D'ÉCRIRE EN CAPITALES.

Item # No de l'article	Description Description	Purchase Date Date d'achat
Retailer's Name Nom du détaillant		
City Ville	State/Province État/Province	Zip/Postal Code Code postal
Country Pays		
Owner's Name Nom du propriétaire		
Address Adresse		
City Ville	State/Province État/Province	Zip/Postal Code Code postal
Country Pays		

**PLEASE READ FIRST**

When carefully installed, this module will provide all the pleasures of high quality, digital onboard sound and the benefits of today's DCC (Digital Command Control) technology. Please note that while each module is tested thoroughly before it is shipped, Bachmann cannot control the correctness of the installation. **It is imperative that you read and follow the information and steps below for a successful installation.**

**IMPORTANT FOR A SUCCESSFUL INSTALLATION**

Before you install your sound module, there are some simple precautions you should take:

**The electronics should be handled carefully in a static-free environment. To discharge static electricity, touch a grounded water pipe or bare sheet metal surface before handling the module.**

- Work in a clean, well-lit area on a non-conductive surface. Stray metal scraps and dirt can get onto the circuitry and cause shorts.
- **NEVER INSTALL THE MODULE WHILE IT IS POWERED.**
- Do not exceed the track output ratings for which the module is designed.
- Do not install the module into a model that it was not designed for.

These instruction assume that you have some understanding of, or experience with DCC. It covers the differences you may need to know between this decoder and any you may have previously used.

Your Bachmann Sound Decoder is both a DCC Sound Decoder and a DC Sound System. The sound decoder performs numerous functions on both Analog (DC) and Digital (DCC or Digital Command Control). The operation of some of these functions will be different depending on which you are using:

- Motor control** — the decoder controls the motor in both DC and DCC, enabling proper coordination of the locomotive's movement with other operating features and sound effects.
- Sound** — Customer-installed speaker required. The authentic sounds of your favorite characters are digitally reproduced through the powerful 3-watt audio amplifier. All sounds are polyphonic; one sound will never interrupt another.
- Lights** — Headlights and/or backup lights are NOT factory installed - however, should you wish to add LEDs, the sound decoder has the ability to turn them on or off in DCC mode using F0 (or F10 on the Bachmann E-Z Command® DCC system).



**WIRING INSTRUCTIONS**

The following diagram will help you to install the decoder. Lighting, volume, and motor wiring instructions are illustrated below.

When connecting wires, use the following considerations and this master wiring diagram as a guide:

- Secure the decoder in place using double-sided foam tape.
- When wiring the decoder, trim all wires to the necessary length. This will prevent wires from interfering with the drive mechanism and being pinched when closing the body shell.
- To ensure long-term reliability, solder all connections.

**Note:**

The following diagram serves as a general guide for reference.

**Use an 8-Ohm speaker rated for 3 watts.**

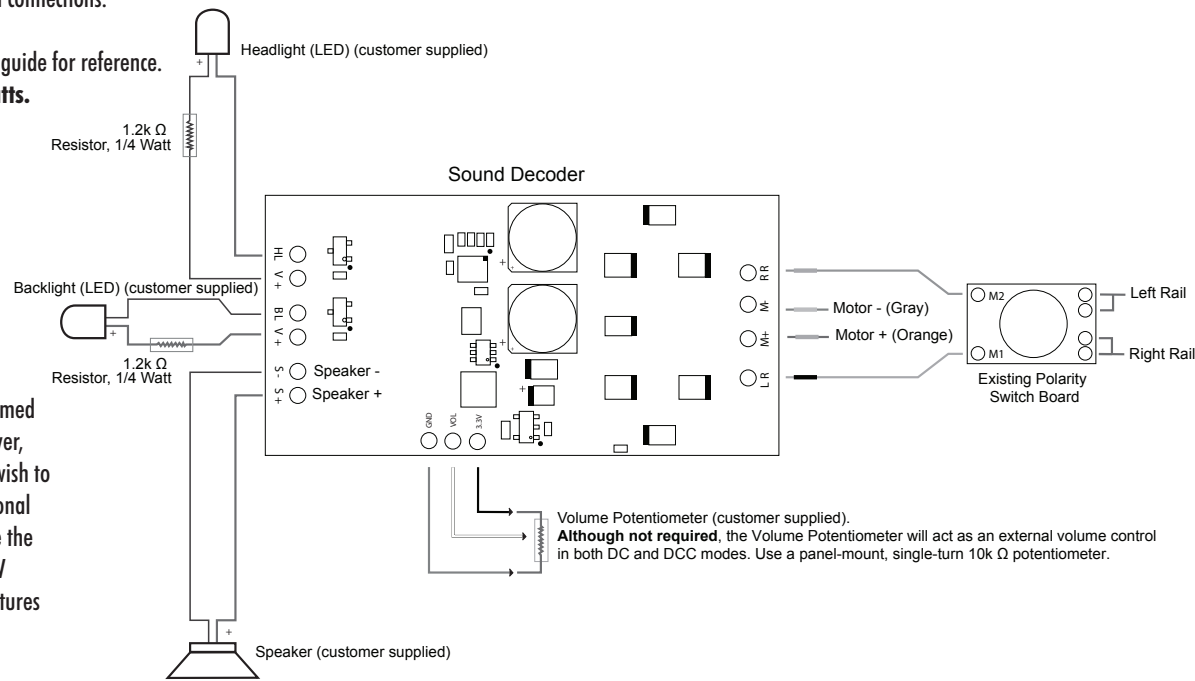

**FEATURES AND SPECIFICATIONS**

The custom decoder has been pre-programmed for a great ready-to-run experience. However, there are features available that you may wish to experiment with or adjust to suit your personal preferences. These adjustments will require the use of a DCC system capable of changing CV values (Configuration Variables). Some features will require a little explanation.

**Sound Features**

The volume levels of the individual sound effects have been pre-adjusted to provide the best possible sound for each character when operating in DCC or DC mode. However you can also adjust the master volume via DCC operation or a customer-installed potentiometer for both DCC and DC operation. See DCC section for adjustment of master and individual sound effects via CV selection.

**Throttle Features**

The Digital Sound Decoder has many advanced throttle features as part of SoundTraxx's Hyperdrive system. With the addition of these features, you will be able to better control your locomotive speed under varying conditions.

**Decoder Specifications**

- Supports extended address mode for assigning any locomotive number up to 9,999.
- Supports advanced consist addressing.
- Supports 'Operation Mode Programming', allowing CVs to be changed on the mainline without using a programming track.

**Throttle Specifications**

- Supports 14, 28 and 128 speed step modes.
- Programmable acceleration, deceleration and starting voltage for prototypical starting and stopping.
- Use of standard and alternate speed tables.

**Additional information about automatic sound functions can be found in the User's Guide available on both the Bachmann (www.bachmanntrains.com) and SoundTraxx (www.soundtraxx.com) websites.**

**OPERATING WITH DCC**

Your locomotive will respond to address 3 as it would if you had just installed any DCC decoder. Your sound decoder has been shipped with all CVs pre-programmed so you can begin using your locomotive immediately without having to worry about what adjustments to make. The locomotive's sound decoder is factory-set with the following "default" function assignments:

Sound Decoder Function Assignments	
Function Key	Default Effect
F0	Lighting (Lights NOT Factory Installed)
F1	Bell On/Off (Toby Only)
F2	Whistle On/Off (All Characters Except Toby)
F3	Short Whistle (All Characters Except Toby)
F4	Blowdown
F5	(Not Assigned)
F6	(Not Assigned)
F7	(Not Assigned)
F8	Mute

For now, simply set your controller to Locomotive 3, place the locomotive on the mainline and see what happens!

**Ring the Bell (Toby Only)**

To ring the bell, press F1 on your controller. This is an on/off function, i.e., once on, the bell will continue to ring the bell sequence until you turn it off by pressing F1 again to turn it off.

**Blow the Whistle (For All Characters Except Toby)**

To activate the Whistle, press F2 on your controller to blow the whistle. The longer you press the key, the longer the whistle will blow. While this allows you to make short or long signals, F3 is designated as a 'short' whistle so you can create whistle signals that will have that nice, crisp, 'toot' regardless of how responsive your controller may be.

**Blowdown**

Press the F4 key to open the blowdown valve (steam hiss). Press the F4 key again to close the blowdown valve.

**Exhaust Chuff**

The exhaust chuff and sounds are automatically generated whenever the locomotive is set into motion.

**Mute the Sound**

Pressing F8 will gradually mute all sound effects. Pressing it a second time will allow you to hear the sounds again.

**Programming the CVs**

As you see, no programming is necessary to begin enjoying your sound system. However... after you have had a chance to play with your decoder for a little while, you may wish to make some changes such as selecting a new address or altering a sound effect. The following section will introduce you to CVs and how and why you might wish to change them.

**What is a CV?**

CV stands for Configuration Variable, which is the industry-adopted term for a decoder's user-programmable memory locations. CVs allow you to customize individual decoder properties such as the address, momentum, throttle response, sound volume and much more. Once a CV has been programmed, the setting will be permanently remembered even after the power has been turned off. A CV can be modified as often as necessary by simply reprogramming it with a new value. These adjustments will require an NMRA-compatible DCC system capable of changing CV values.

The factory installed decoders are preset so that they ship with the proper "voices". Items such as the exhaust chuff rate have already been calculated and optimized for the locomotive. The decoder is set to operate immediately using either a 12 Volt DC power pack or NMRA-compatible DCC command station.

**Programming Procedure**

As each DCC system is different, the procedure for programming a CV will vary depending upon the system. Unfortunately, we cannot provide detailed instructions to cover every command station and have to assume that you have some level of understanding regarding its capabilities and operating procedures. For specific programming procedures, please consult your DCC system manual.

**Resetting the CVs or Starting Over**

Occasionally, something goes wrong and the sound system will not respond as expected. Usually, this is caused by one or more CVs being programmed to the wrong value. All CVs can be quickly reset to their factory default values using the following procedure.

1. Program CV 8 to a value of 8 using either Service Mode or Operations Mode.
2. Place the locomotive on a powered section of track. If locomotive is already on the mainline, turn power to the track off and then back on.
3. After power is restored to the track there should be no indication of activity for a period of six seconds. If sound comes on immediately upon restoring power, the decoder did not reset. Repeat steps 1 and 2.
4. Once the six-second period has elapsed, the sound should come on indicating that the CVs were successfully reset.
5. The decoder will now respond to short address 3 just as it did when it was first used or installed and all CVs are now reset to original factory-programmed (default) values.

**Sound Volume**

CV 128 selects the Master Sound Volume for each character. This adjustment will adjust the overall volume up or down of all the sounds associated with the character.

Note: If your locomotive has a volume control knob, it must be ON. Make sure that it is turned up enough so that you can hear your changes before entering a value into CV 128. In addition to the Master Volume CV, the following individual sound volumes can be adjusted:

Sound Volume CVs			
CV	Description	Range	Default
128	Master Volume	0 - 255	125
129	Whistle Volume	0 - 255	195
130	Bell Volume	0 - 255	125
131	Steam Exhaust Volume	0 - 255	150
136	Blowdown Volume	0 - 255	135
137	Steam Release Volume	0 - 255	64

**Selecting a Different Character**

Please note that not all characters have all sound effects! If for some reason you wish to select a different "character", adjust the value in CV 115 (Character Select CV) as follows:

CV 115, Character Selection	
Character	CV Value
Thomas	0 (factory setting)
Percy	1
Edward	2
James	3
Henry	4
Gordon	5
Toby	6
Spencer	7
Emily	8

**PROGRAMMING AND READING CVs**

If your decoder is otherwise working properly (i.e., responds properly on the mainline to speed and direction commands) but your command station is having trouble reading CV data, it may be due to incompatibilities between the electrical requirements of the decoder (which are different from conventional decoders due to the added audio circuitry) and the electrical characteristics of your programming track. In such an event, you will need to use a Programming Track Booster, such as SoundTraxx PTB-100 (P.N. 829002). The PTB-100 amplifies the programming track signals to levels that work best with Tsunami. It is easy to install (see diagram to right) and inexpensive. An advantage to using the PTB-100 is that it also provides short-circuit detection and some helpful diagnostics.

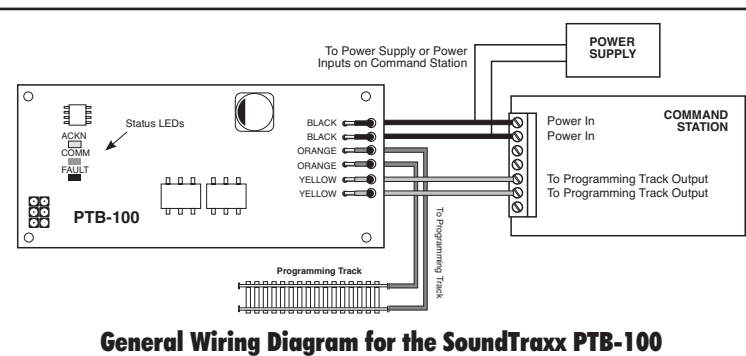

**General Wiring Diagram for the SoundTraxx PTB-100**