

When operating in analog mode, DO NOT exceed the module's input voltage rating of 27 volts. **When your track voltage exceeds 22 volts, the module will automatically shut off the sound and motor and flash the front and rear lights: back down on the throttle immediately.**

Important: Your sound module will work best in analog mode when using a high quality, electronically regulated power pack, preferably one that supplies smooth, filtered DC power. Older rheostat style power packs and pulse power packs will result in erratic and unreliable operation and should not be used with this sound module. If your power pack provides a pulse power switch, leave it in the 'Off' position.

Depending on the quality of the power pack's track voltage, some automatic sound functions such as the grade crossing whistle may require a lower sensitivity setting than needed for DCC operation to avoid continual triggering of the sound effect.

Automatic Sound Configuration Register

CV 197 selects which automatic sound functions are enabled when the decoder is operating in analog or DC mode. This has been preset to have the Automatic Whistle Signals activated so that whenever the locomotive is stopped or started, the sound module will produce the correct whistle signal appropriate for the direction of travel:

One Short Toot = Stop
Two Medium Toots = Forward
Three Short Toots = Reverse

There are four additional sound features that can be programmed for automatic operation using a DCC system:

1. Automatic Grade Crossing Signal - When enabled, the sound module will play a grade crossing signal (two long whistle blasts followed by a short and another long) triggered by a sudden upward spike in the throttle.
2. Automatic Bell - With this feature activated, the sound module will turn the bell on and off at preset speed points such as might occur when passing through a yard or station platform.
3. Automatic Steam Release - If turned on, this feature will cause a short steam release to sound whenever the locomotive is brought to a stop.
4. Automatic Brake Squeal - The brake squeal can be activated by slowing the train down by a predetermined amount.

Additional information about automatic sound functions can be found in the User's Guide.

For service/repair, contact the Bachmann Service Department by visiting www.bachmantrains.com/home-usa/service.php, calling 1-800-356-3910 (toll-free within the U.S. and Canada), or emailing service@bachmantrains.com. Bachmann's Service Department is available Monday through Friday, 8:00 am to 4:00 pm ET. Please be aware you may need to leave a message on our voice mail system. Your call will be returned as soon as a service technician is available. We thank you in advance for your patience.



Bachmann Industries Inc.; 1400 East Erie Avenue; Philadelphia, PA 19124 USA • www.bachmantrains.com

Notice

The information in this document is subject to change without notice.

Neither Bachmann Industries, Inc. nor SoundTraxx (Throttle Up!) shall be liable for technical or editorial errors or omissions contained herein; nor for incidental or consequential damages resulting from the furnishing, performance or use of this material.

This document contains information protected by copyright. No part of this document may be photocopied or reproduced in any form without the prior written consent of Bachmann Industries, Inc.

Product names mentioned herein may be trademarks and/or registered trademarks of their respective companies.

Bachmann and Spectrum are registered trademarks of Bachmann Industries, Inc.

SoundTraxx and Tsunami are registered trademarks of Throttle Up! Corp. SoundTraxx DCC, Digital Sound Decoder, Dynamic Digital Exhaust, Auto-Exhaust and Hyperlight are trademarks of Throttle Up! Corp.

Instructions for the Bachmann Spectrum® HO 50-Ton Two-Truck Climax Sound Module

Spectrum®



www.bachmantrains.com

PLEASE READ FIRST

Congratulations on the purchase of this SoundTraxx® Tsunami® Digital Sound Module from Bachmann. This module has been specifically designed for installation in your Spectrum locomotive. When carefully installed, the module will provide all the pleasures of high quality, digital onboard sound and the benefits of today's DCC (Digital Command Control) technology. Please note that while each module is tested thoroughly before it is shipped, Bachmann cannot control the correctness of the installation. **It is imperative that you read and follow the information and steps below for a successful installation.**

Module Features

- 16+ Sound Effects
- 16-Bit Sound Processor
- 7-Band Equalizer
- Reverb
- 3 Selectable Whistles Built in
- 14 Functions

Steam Effects

- Steam Exhaust Chuff
- Bell
- Long Whistle
- Short Whistle
- Airpump
- Dynamo
- Water Stop
- Brake Squeal
- Brake Release
- Side Rod Clank
- Sniffer Valve
- Johnson Bar/Power Reverser
- Firebox Blower
- Cylinder Blowdown (Hiss)
- Coupler Clank

MODULE RATINGS

Track Voltage: 27 Volts Maximum

IMPORTANT FOR A SUCCESSFUL INSTALLATION

Before you install your sound module, there are some simple precautions you should take:

The electronics should be handled carefully in a static-free environment. To discharge static electricity, touch a grounded water pipe or bare sheet metal surface before handling the module.

- Work in a clean, well-lit area on a non-conductive surface. Stray metal scraps and dirt can get onto the circuitry and cause shorts.
- **NEVER INSTALL THE MODULE WHILE IT IS POWERED.**
- Do not exceed the track output ratings for which the module is designed.
- Do not install the module into a model that it was not designed for.

Installation

1. Before installing the sound module, the factory-equipped motor decoder must first be reset to factory defaults. (If the model has never been run or its original CV settings have never been changed, this will not be necessary.) To reset to factory defaults using your DCC command station, set CV 8 to a value of 8. Then cycle the locomotive's power by turning it off and back on.
2. Referring to the diagram, remove the coal load in the tender by gently pulling up on the water hatch.
3. Carefully align the 21-pin header on the sound module with the like connector on the circuit board inside the tender. The board will only mount one way as shown in the illustration. Take care not to bend any of the pins!
4. Once you are sure you have the pins and the socket properly aligned, press the module into place. Replace the coal load in the tender.

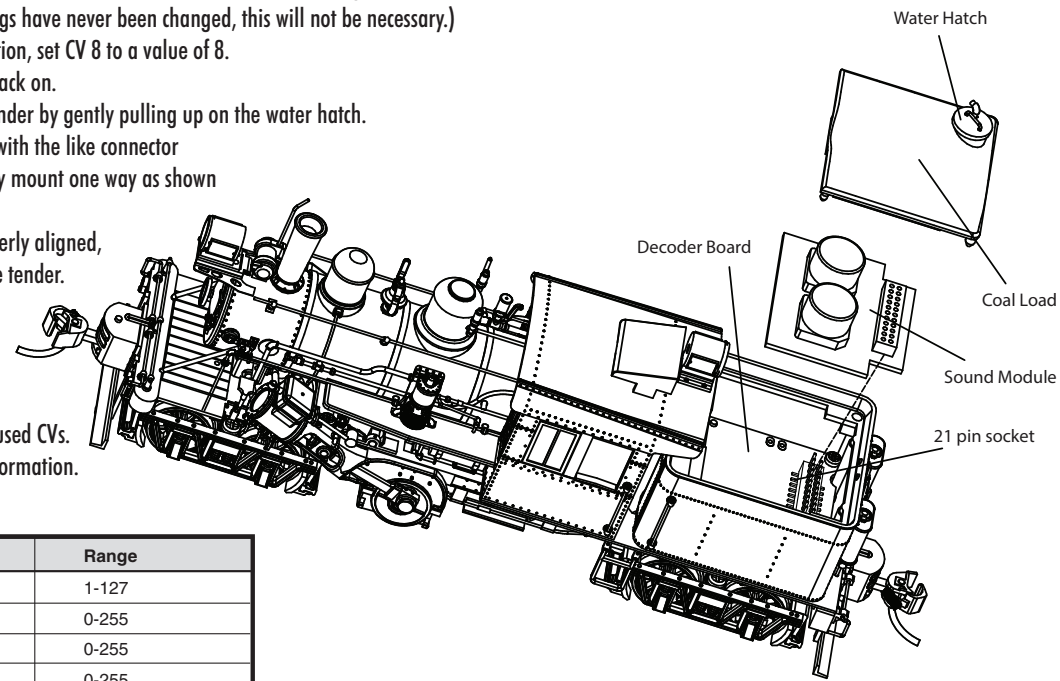

Operation

This table is a partial list of the Tsunami's most commonly used CVs. Please refer to the online Owner's Manual for complete information.

CV	Name	Range
CV1	Primary Address	1-127
CV 2	Start Voltage	0-255
CV 3	Acceleration Rate	0-255
CV 4	Braking Rate	0-255
CV 17,18	Extended Address	0-9999
CV 19	Consist Address	0-127
CV 29	Decoder Configuration	See Online Manual
CV 115	Whistle Select	0 - 2
CV 128	Master Volume	0-255

If you are new to SoundTraxx Digital Sound Modules, you should start with the **User's Guide** that will walk you through the various aspects of programming your sound module, as well as some tips on troubleshooting. For the power user, the **Technical Reference** will provide a list of all the CVs available for use with your sound module and their exact function and make-up for those who wish to have a complete reference for advanced programming techniques. These documents are available in PDF format on the Bachmann website (www.bachmanntrains.com) and the SoundTraxx website (www.soundtraxx.com). Please note that you need to have Adobe® Acrobat Reader installed on your computer (available as a free download from www.adobe.com) to open and print these files.

Your Digital Sound Module has been installed with all CVs pre-programmed so you can begin using your locomotive immediately without having to worry about what adjustments to make. Items such as the exhaust chuff rate have already been calculated and optimized for the locomotive. The module is set to operate immediately using either a 12 volt DC power pack or NMRA-compatible DCC command station.

Since CVs are pre-programmed for individual models to achieve the best possible sound and operation, default values will vary from locomotive to locomotive. You can find the default values for each model listed on the Bachmann website (www.bachmanntrains.com).

Operating with DCC

Your locomotive will respond to address 3 as it would if you had just installed any DCC decoder. Since these modules have two rather than four lighting outputs, we have made some changes to the standard function assignments so that those using command stations with limited function keys can access some additional sound functions. The list below shows the function assignments of the module. The User's Guide located on either the Bachmann or SoundTraxx website will give you all the information you need to adjust your module to suit your taste.

For now, simply set your controller to Locomotive Address 3, place the locomotive on the track, and away you go!

Function Assignment

- | | |
|-----------------------|--------------------|
| F0 = Headlight On/Off | F5 = Dynamo |
| F1 = Bell | F6 = Water Stop |
| F2 = Long Whistle | F7 = Coupler Clank |
| F3 = Short Whistle | F8 = Audio Mute |
| F4 = Steam Release | |

Programming and Reading CVs

If your decoder is otherwise working properly (i.e., responds properly on the mainline to speed and direction commands) but your command station is having trouble reading CV data, it may be due to incompatibilities between the electrical requirements of the decoder (which are different from conventional decoders due to the added audio circuitry) and the electrical characteristics of your programming track. In such an event, you will need to use a Programming Track Booster, such as SoundTraxx PTB-100 (P.N. 829002). The PTB-100 amplifies the programming track signals to levels that work best with Tsunami. It is easy to install (see next page) and inexpensive. An advantage to using the PTB-100 is that it also provides short-circuit detection and some helpful diagnostics.

General Wiring Diagram for the SoundTraxx PTB-100

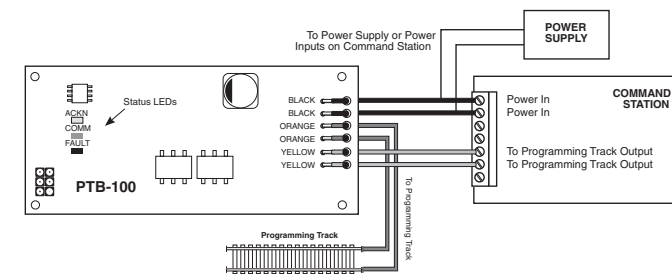

Operating in Analog Mode Using a DC Power Pack

While the sound system installed in your Bachmann model is primarily designed for operation by a DCC control system, it may be used on a DC powered layout. To operate in analog mode, you simply control your locomotive using an ordinary power pack, although operation will be a bit different than when running non-decoder equipped locomotives.

With the power pack's throttle set to zero, the sound module will be silent as it has no power. The throttle must be turned up to around 5 volts or so to provide sufficient voltage to power up the internal circuitry of the module. At this point you will begin to hear locomotive sounds.

Increasing the throttle further to around 9 volts or so will set the locomotive in motion, increasing speed as the throttle is turned up. Note that the direction of the locomotive can only be changed when the locomotive is stopped.

90 DAY LIMITED WARRANTY FOR SOUND MODULE
purchased in the United States and Canada

effective November 1, 2011, this warranty supersedes all previous (and/or concurrent) warranties

This sound module is warranted to the original purchaser for a period of ninety (90) days from the original purchase date — under normal use and service — against defective materials or workmanship. This warranty is given in lieu of all other express warranties. All implied warranties, including but not limited to implied warranties of fitness and merchantability, shall expire ninety days from the date of purchase. Some jurisdictions do not allow limitations on how long an implied warranty lasts, so the above limitation may not apply to you.

This warranty is void if the component has been damaged by accident or unreasonable use, neglect, improper service or other causes **including improper installation** not arising out of defects in material or workmanship. BACHMANN SHALL NOT BE LIABLE FOR INCIDENTAL OR CONSEQUENTIAL COSTS, EXPENSES OR DAMAGES INCURRED BY THE PURCHASER. Some jurisdictions do not allow the exclusion or limitation of incidental or consequential damages, so the above limitation or exclusion may not apply to you.

This warranty gives you specific legal rights, and you may also have other rights which vary from location to location. In order to validate this warranty, the accompanying Owner Registration Card must be completed and mailed within ten (10) days after purchase of the module to the address listed below:

Send Owner Registration Card and direct inquiries to:

Attention: Service Department
Bachmann Industries, Inc.; 1400 East Erie Avenue; Philadelphia, PA 19124 USA
Telephone: 800-356-3910 (toll free within the United States and Canada only)
Telephone: 215-533-1600 (for all countries)
E-mail: service@bachmanntrains.com

For residents of the U.S. and Canada only, please fill in and mail this card within 10 days after purchase to validate warranty. PLEASE PRINT.

Pour les résidents des É.-U. et du Canada seulement : prière de remplir cette fiche et de la poster dans un délai de 10 jours après l'achat afin de valider la garantie. PRIÈRE D'ÉCRIRE EN CAPITALES.

Item # No de l'article	Description Description	Purchase Date Date d'achat
Retailer's Name Nom du détaillant		
City Ville	State/Province État/Province	Zip/Postal Code Code postal
Country Pays		
Owner's Name Nom du propriétaire		
Address Adresse		
City Ville	State/Province État/Province	Zip/Postal Code Code postal
Country Pays		